

NOTES:

1 FOR UNITS BUILT PRIOR TO 09/08/2011, USE 260 FOR REAR COVER KIT.

2 HEART RATE WIRE HARNESS IS NOT FIELD REPLACEABLE, ORDER 37.

5.23 - 10/5.23 - 11	P/N : 300799-102	SUBREV : F
DRAWN BY : KAW	DATE : 9.6.12	SHEET 1 OF 4

D

C

B

A

4

3

2

1

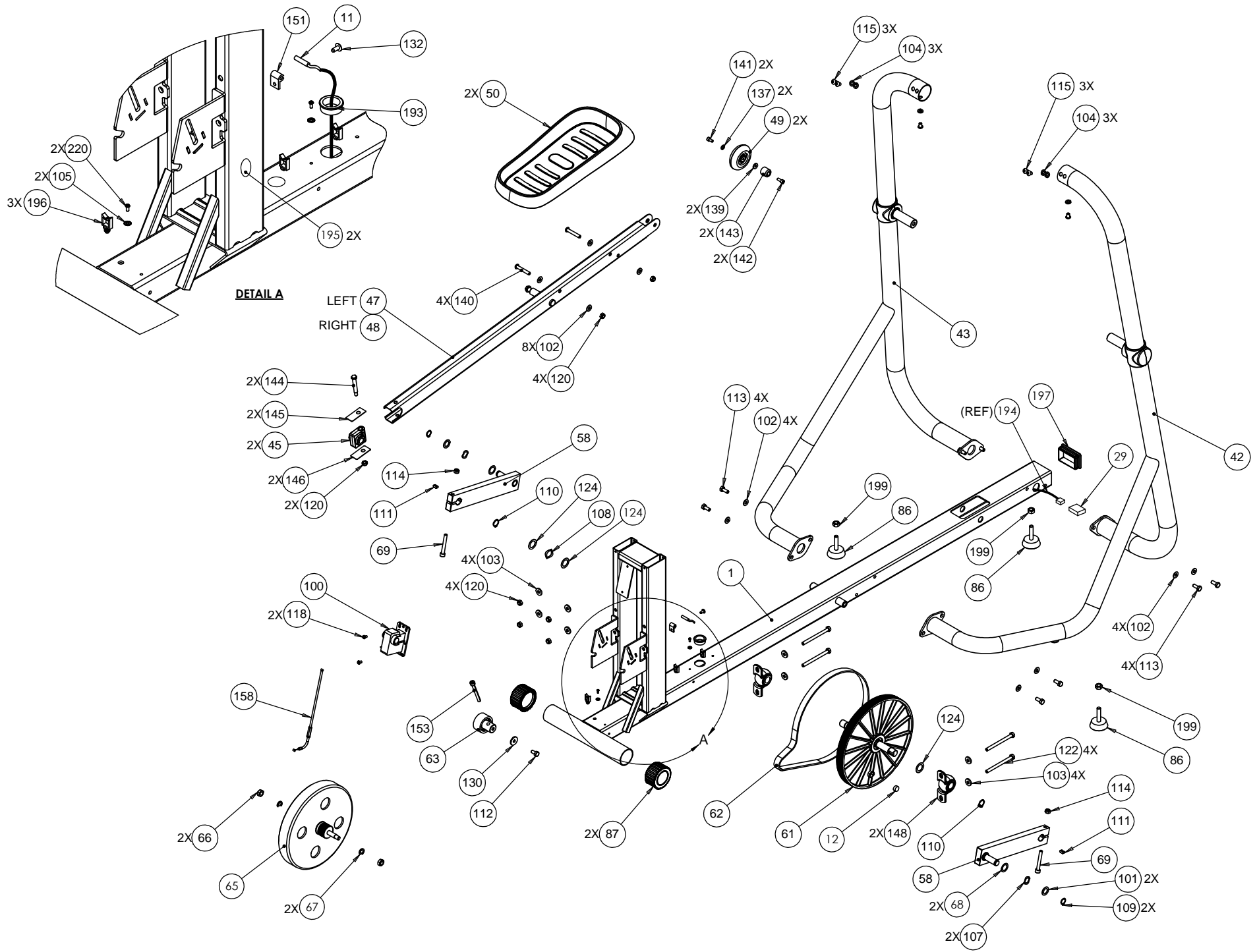

DETAIL A

LEFT 47
RIGHT 48

4

3

2

1

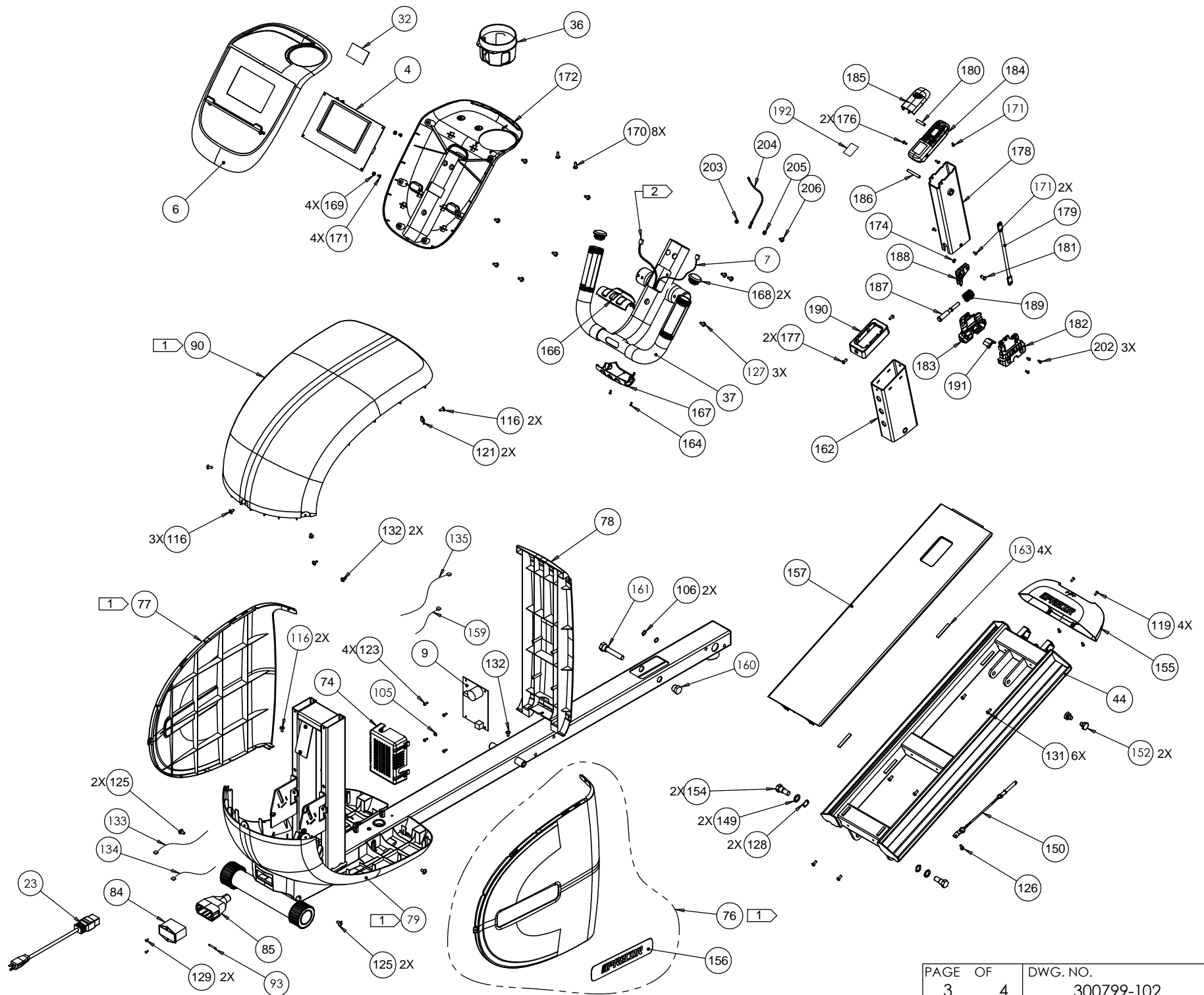

4

3

2

1

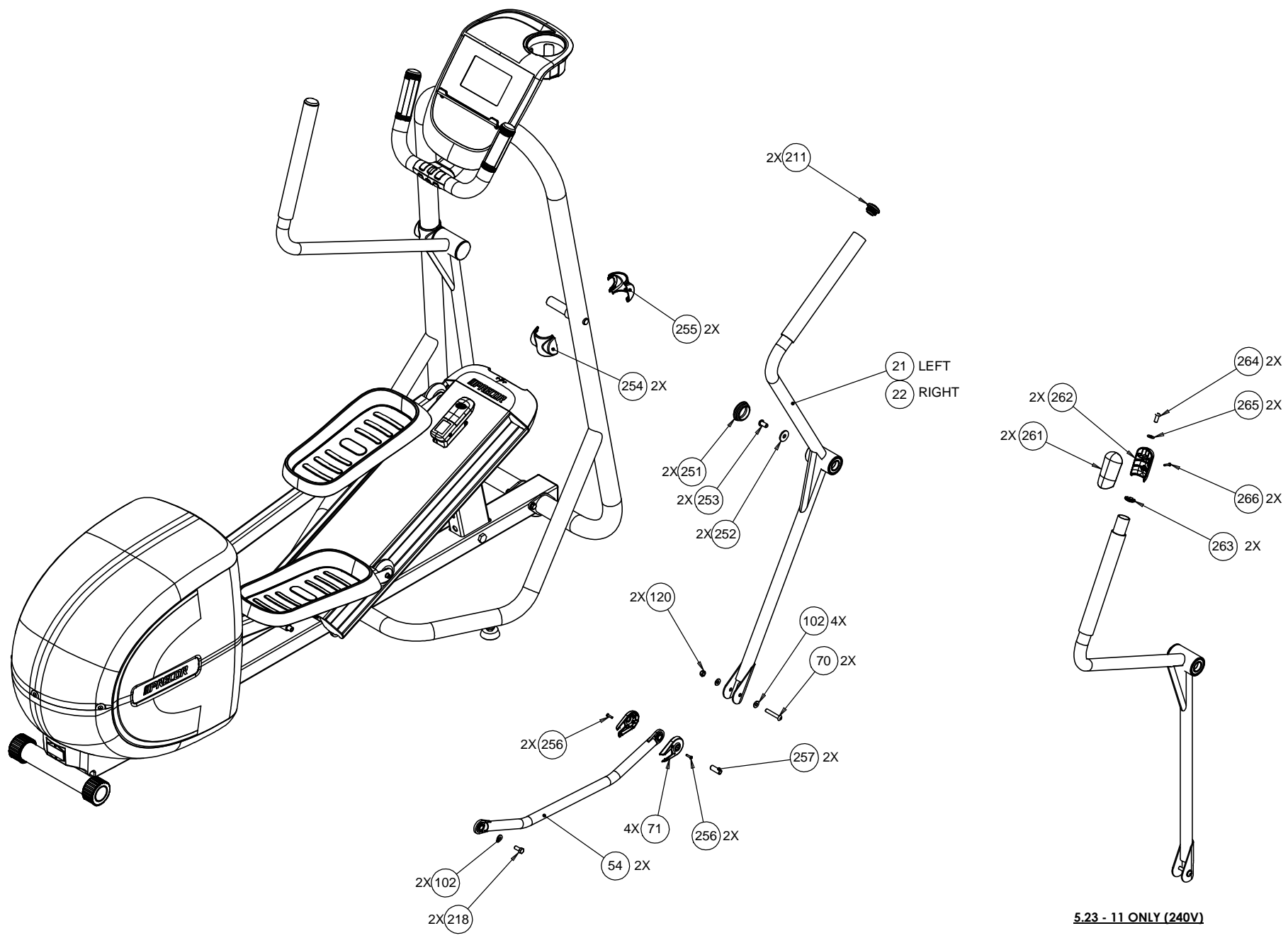

5.23 - 11 ONLY (240V)

Bubble #	OEM Number	Part Description
4	PPP000000RX31H1000	
6	PPP000000RX31NL000	FRONT PANEL ASSY 5.21,5.23
7	PPP000000RX2R2X000	WIRE HARNESS MAIN
9	PPP000000RX35CU002	ASSY,LPCA & SW,5.23/5.21, V3.0 (CON
11	PPP000000RX31FW000	REED SWITCH(REXON P/N 10H131FW)
12	PPP000000RX01H5000	MAGNET
21	PPP000000RX2SMQ000	LEFT LEVER ARM. GRAPHITE
22	PPP000000RX2SMR000	RIGHT LEVER ARM. GRAPHITE
23	PPP000000RX2Q2V000	POWER CABLE(REXON P/N 10E72Q2V)
29	PPP000000RX2S9Y000	
32	PPP000000RX31VH000	ASSY,PCA, HEART RATE
36	PPP000000RX2S74000	WATER BOTTLE HOLDER (REXON P/N 10E9
37	PPP000000RX31MX000	CONSOLE MAST ASSY
42	PPP000000RX2UA2000	FRONT SUPPORT TUBE ASSY-RIGHT
43	PPP000000RX2UA1000	FRONT SUPPORT TUBE ASSY-LEFT
45	PPP000000RX2WYA000	SHAFT SLEEVE ASS'Y
47	PPP000000RX2RCQ000	STAIRARM WELDMENT, LH
48	PPP000000RX2RBG000	STAIRARM WELDMENT, RH
49	PPP000000RX30VL000	ROLLING WHEEL ASS'Y(REXON P/N 10H13
50	PPP000000RX2S6M000	PEDAL
54	PPP000000RX2SMN000	LINKAGE ASSY
58	PPP000000RX30V6000	CRANK ASS'Y(REXON P/N 10H130V6)
61	PPP000000RX30VK000	PULLEY ASS'Y(REXON P/N 10H130VK)
62	PPP000000RX2JTH000	DRIVE BELT, POLY-V BELT
63	PPP000000RX30VJ000	IDLER WHEEL ASS'Y(REXON P/N 10H130V
65	PPP000000RX31GW000	MAGNETIC BRAKE ASS'Y(REXON P/N 10H1
66	PPP000000RX21BB000	NUT
67	PPP000000RX0J9C000	SPRING WASHER(REXON P/N 2502AZC410)
68	PPP000000RX0J5W000	FLAT WASHER(REXON P/N 2501MNN340)
69	PPP000000RX32GH000	HEX. SOC. HD. CAP BOLT(REXON P/N 26
70	PPP000000RX21RE000	HEX. SOC. TRUSS HD. SCREW

71	PPP000000RX2S5N000	BEARING COVER
74	PPP000000RX2S7B000	COVER
76	PPP000000RX370E000	SIDE COVER ASSY, RH
77	PPP000000RX370F000	SIDE COVER ASSY, LH
78	PPP000000RX2S7C000	FRONT HOUSING
79	PPP000000RX370G000	ASSEMBLY, COVER, REAR BOTTOM
84	PPP000000RX32J3000	AC SOCKET ASS'Y(REXON P/N 10H132J3)
85	PPP000000RX32EG000	BOOT,A/C CABLE,RADIUS POWER,UL
86	PPP000000RX26LH000	LEVELING PAD(REXON P/N 10B826LH)
90	PPP000000RX3701000	UPPER COVER
100	PPP000000RX01HL000	D.C MOTOR ASS'Y(REXON P/N 1A503003A
101	PPP000000RX0J52000	FLAT WASHER(REXON P/N 2501MBDN47)
102	PPP000000RX0J5G000	FLAT WASHER,8 X 18 X 1.5, STEEL, E-
103	PPP000000RX0J7B000	FLAT WASHER(REXON P/N 2501NBDN22)
104	PPP000000RX0J94000	SPRING WASHER(REXON P/N 2502ABC416)
105	PPP000000RX0JAE000	EXTERNAL TOOTH LOCK WASHER
106	PPP000000RX0JB2000	WAVE WASHER(REXON P/N 2506MBN612)
107	PPP000000RX0JB4000	WAVE WASHER(REXON P/N 2506MBN616)
109	PPP000000RX0JED000	C-RING(REXON P/N 2570BBN116)
110	PPP000000RX0JFP000	C-RING(REXON P/N 2570HBN120)
111	PPP000000RX0JGD000	PARALLEL KEY(REXON P/N 2571MNC319)
112	PPP000000RX0JP4000	HEX. HD. BOLT(REXON P/N 2601BBDAA9)
113	PPP000000RX0JPU000	HEX. HD. BOLT
114	PPP000000RX0KQZ000	NUT(REXON P/N 2705FBD110)
115	PPP000000RX0K04000	HEX. SOC. TRUSS HD. SCREW
116	PPP000000RX0K99000	CR. RE. TRUSS HD. TAPPING SCREW
118	PPP000000RX0KAE000	CR.RE. PAN HD. TAPPING SCREW
119	PPP000000RX0KAP000	CR.RE. PAN HD. TAPPING SCREW
120	PPP000000RX0KQY000	LOCK NUT
121	PPP000000RX0KRK000	U-TYPE NUT
122	PPP000000RX0WRG000	HEX. HD. BOLT

123	PPP000000RX1479000	CR.RE. PAN HD. TAPPING SCREW
124	PPP000000RX1568000	FLAT WASHER
125	PPP000000RX0KQY000	LOCK NUT
125	PPP000000RX22R9000	CR.-RE. TRUSS HD. SCREW
126	PPP000000RX22XT000	HEX.SOCKET HD.CAP SCREWS
127	PPP000000RX2B5V000	CR.-RE. TRUSS HD. SCREW
129	PPP000000RX2ENV000	CR. RE.COUNT HD. TAPPING SCREW
130	PPP000000RX2JS2000	FLAT WASHER
131	PPP000000RX0KCX000	PAN HD PLAIN WASHER SELF TAPPING SC
132	PPP000000RX2PHA000	CR. RE. TRUSS HD. TAPPING SCREW
133	PPP000000RX32GW000	WIRE HARNESS MAIN(REXON P/N 10H132G
134	PPP000000RX2R2Z000	GND WIRE(REXON P/N 10E92R2Z)
135	PPP000000RX2RKD000	GND WIRE(REXON P/N 10E92RKD)
137	PPP000000RX0J4E000	FLAT WASHER
139	PPP000000RX0J74000	FLAT WASHER
140	PPP000000RX21RE000	HEX. SOC. TRUSS HD. SCREW
141	PPP000000RX2NAN000	HEX. SOC. HD. CAP BOLT
142	PPP000000RX2RYF000	HEX. SOC. HD. CAP BOLT
143	PPP000000RX3TWY000	ANCHOR BLOCK(REXON P/N 10H13TWY)
144	PPP000000RX2SEW000	SPECIAL BOLT(REXON P/N 10E92SEW)
145	PPP000000RX2UVP000	BUMPER
146	PPP000000RX2UVQ000	BUMPER
150	PPP000000RX2SQ0000	LATCH(REXON P/N 10E92SQ0)
151	PPP000000RX2UJ3000	REED SWITCH BRACKET(REXON P/N 10F62
152	PPP000000RX2ULS000	CLAMP BOLT
153	PPP000000RX2YQ3000	HEX. SOC. HD. CAP BOLT(REXON P/N 26
154	PPP000000RX30WG000	SPECIAL BOLT(REXON P/N 10H130WG)
155	PPP000000RX30V0000	FRONT HOUSING
157	PPP000000RX31D6000	RAMP COVER, 5.21,5.23
158	PPP000000RX31FU000	BRAKE LEADWIRE(REXON P/N 10H131FU)
159	PPP000000RX31FV000	LEAD WIRE ASS'Y(REXON P/N 10H131FV)

160	PPP000000RX31HQ000	SPECIAL NUT(REXON P/N 10H131HQ)
161	PPP000000RX31HR000	SPECIAL BOLT(REXON P/N 10H131HR)
162	PPP000000RX31K9000	SUPPORTING TUBE ASS'Y
163	PPP000000RX32EF000	FOAM(REXON P/N 10H132EF)
164	PPP000000RX2NTM000	CR.RE. PAN HD. TAPPING SCREW
166	PPP000000RX2SG1000	CONSOLE MAST COVER
167	PPP000000RX2SG2000	CONSOLE MAST COVER
168	PPP000000RX2SJV000	END CAP(REXON P/N 10E92SJV)
169	PPP000000RX0J66000	FLAT WASHER
170	PPP000000RX0K94000	CR. RE. TRUSS HD. TAPPING SCREW(REX
171	PPP000000RX0KAK000	CR.RE. PAN HD. TAPPING SCREW
172	PPP000000RX2S72000	BOTTOM CONSOLE PANEL (REXON P/N 10E
173	PPP000000RX31GZ000	KEY PANEL,DISPLAY,5.23/5.21,CASCADE
174	PPP000000RX0JEU000	E-RING
176	PPP000000RX0KD7000	CR. RE. PAN HD. SCREW
177	PPP000000RX0KAE000	CR.RE. PAN HD. TAPPING SCREW
178	PPP000000RX31H9000	CONNECTOR ASS'Y
179	PPP000000RX31HC000	LINK BAR
180	PPP000000RX31HD000	BOTTOM BRACKET CARTRIDGE
181	PPP000000RX31HE000	BOTTOM BRACKET CARTRIDGE
182	PPP000000RX31HF000	PIVOT-SUPPORT(R)
183	PPP000000RX31HG000	PIVOT-SUPPORT(L)
184	PPP000000RX31HH000	TENSION HANDLE
185	PPP000000RX31HJ000	END CAPS
186	PPP000000RX31HK000	SHAFT-PIVOT
187	PPP000000RX31HL000	LOCATING BAR
188	PPP000000RX31HM000	PIVOT-SUPPORT
189	PPP000000RX31HN000	COMPRESSION SPRING
190	PPP000000RX31HP000	BUSH
191	PPP000000RX31M4000	BUMPER
192	PPP000000RX31QA000	WARNING STICK LABEL(REXON P/N 10H13

193	PPP000000RX21BF000	STRAIN RELIEF
194	PPP000000RX2R2W000	ASSY,CBL,COUPLER-UPCA
195	PPP000000RX2RJP000	EARTH LABEL(REXON P/N 10E92RJP)
196	PPP000000RX2SDE000	CORD CLAMP
197	PPP000000RX31KA000	END CAP(REXON P/N 10H131KA)
199	PPP000000RX0KNM000	HEX. NUT
201	PPP000000RX31NC000	TOOL KIT
202	PPP000000RX2RYK000	CR. RE. PAN HD. TAPPING SCREW
203	PPP000000RX0KND000	HEX NUT
204	PPP000000RX2872000	CBL,1C,18AWG,#10 RING/187X032 QD RE
205	PPP000000RX0JAF000	EXTERNAL TOOTH LOCK WASHER(REXON P/
206	PPP000000RX0K4R000	CR RE TRUSS HD SCREW
211	PPP000000RX2SJV000	END CAP(REXON P/N 10E92SJV)
214	PPP000000RX0JEE000	C-RING
218	PPP000000RX2T03000	HEX. HD. BOLT(REXON P/N 26012T03)
220	PPP000000RX0KBP000	CR.RE. PAN HD. TAPPING SCREW
250	PPP000000012223250	FUSE,TIME-DELAY,2.5A,250V,5X20MM
251	PPP000000RX32X0000	END CAP(REXON P/N 10H132X0)
252	PPP000000RX2MPQ000	FLAT WASHER
253	PPP000000RX2N7U000	HEX. SOC. TRUSS HD. SCREW
254	PPP000000RX2SZ1000	END CAPS
255	PPP000000RX2SZ2000	END CAPS
256	PPP000000RX32FF000	CR. RE. PAN HD. TAPPING SCREW
257	PPP000000RX2RBU000	LINK SHAFT(REXON P/N 10E92RBU)
260	PPP000000RX370J000	KIT, REARE COVERS, 5.2X-10/11